

ABLOY® DC270 door closer

This closer is designed especially for ships and extremely heavy doors with guide rail. It is double closer model where DC247 and DC250 are installed to the same mounting plate under same metal cover.



Features

- Adjustable closing force size EN 6-7 with guide rail according EN1154
- Separate adjustment for closing and latching speed using only adjusting valves of DC247
- Back check (BC) as a standard feature
- Wide operating temperature range: -15°C...+45°C
- Adjustable latching and back check starting angle because of the grooved spindle
- Die-cast aluminium body manufactured from high performance silicon alloy
- Meets shipbuilders requirements even when the door is tilted 3,5°

Adjustment

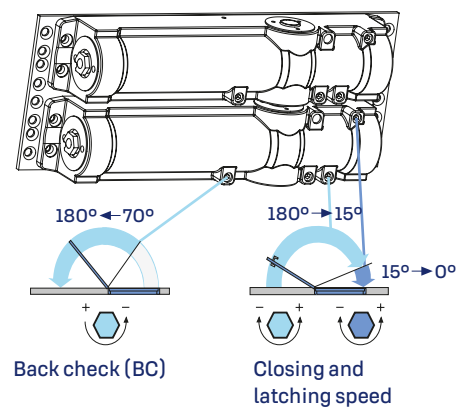

Installation

