



iSWITCH

SISTEMAS DE GESTIÓN DE ENERGÍA ENERGY MANA- GEMENT SYSTEMS

iSWITCH Enkoa basic - magnetic stripe
energy saver

ENKOA energy savers **enable saving up to 60% in the electrici-
ty bill** at the installed buidings.

Our products are designed to meet the needs of the following
markets:

hotels/aparthotel, retirement homes, student housing, universi-
ties, office or government buildings...

WE MAKE
SENSE

ENKOA

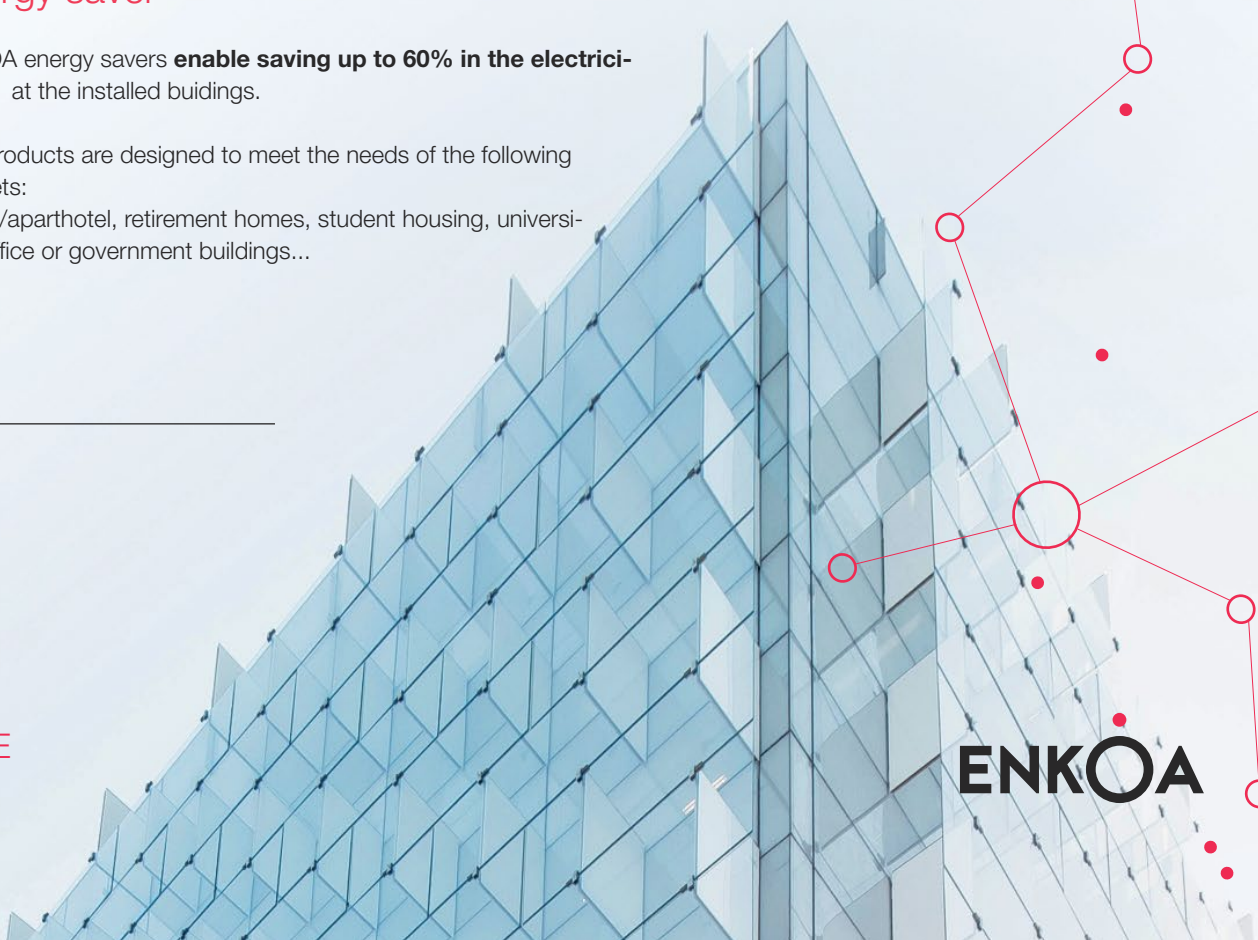
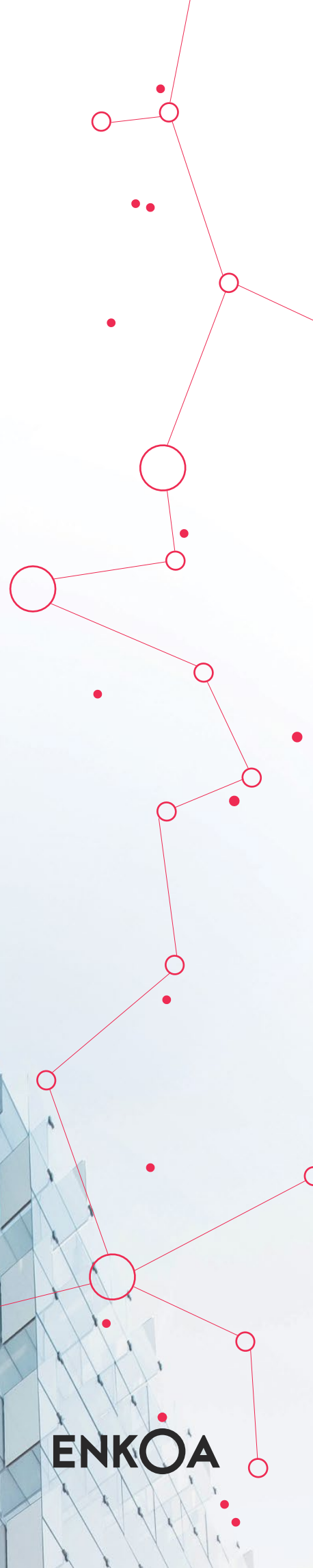



ISWITCH ENKOA BASIC -MAGNETIC STRIPE ENERGY SAVER



Characteristics

DESCRIPTION	iSWITCH Enkoa basic magnetic stripe energy saver
REFERENCE	DEEBxxBx0S
POWER	100 -240 V~
CONSUMPTION	Nominal 30 mA. Max. 50mA (240V~).
OUTPUT RELAY	<p><u>2 relays:</u> One according to net voltage and the other one free voltage.</p> <p><u>Cutting power:</u> 12 A, 240 V~, cos φ = 1</p>
FREQUENCY	50/60 Hz.
WEIGHT	210 grs.
HOUSING	Fireproof material (according to norm UL 94 V-0)

Dimensions

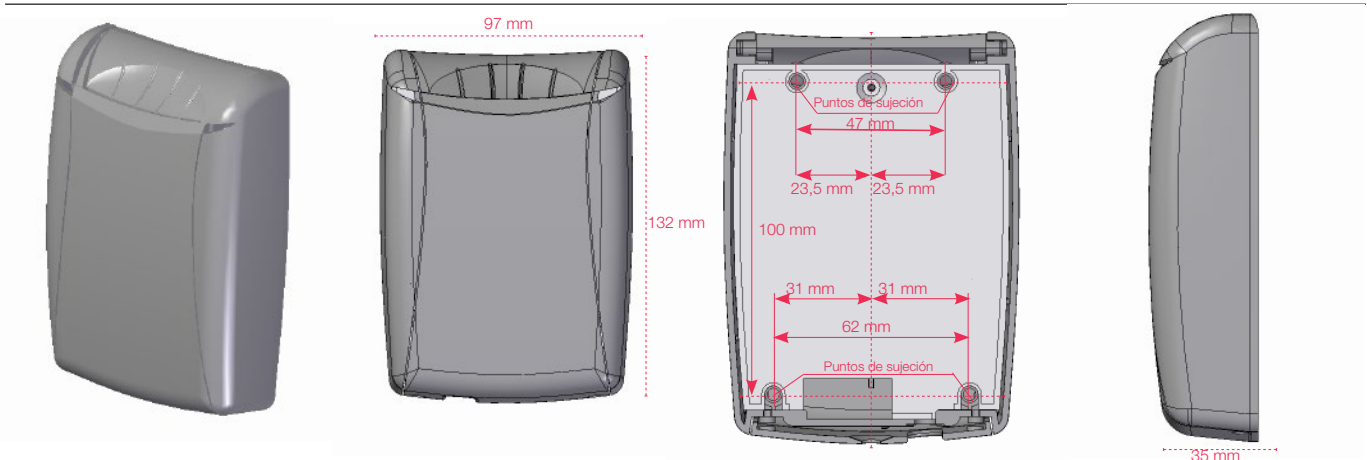

Benefits

ENERGY SAVING It turns power off when the guest leaves the room, to prevent from air conditioning, lighting...to be left on.

INTELLIGENT. It works only with the valid card for each installation.

COMFORT. Temporized courtesy light and possibility to control the access to the minibar, phone, water...

MULTIAPPLICATION . It uses the same credential use for the room access. (magnetic stripe)



Enkoa System S.L.

Polígono Erramone 45, 20850 Mendaro. Gipuzkoa. Spain
T +34 943 757 000 | info@enkoa.com
www.enkoa.com

