

SH-GBD
TWO WAY WIRELESS
GLASS BREAK DETECTOR



INSTRUCTION MANUAL

PRODUCT FEATURES

The SH-GBD is an Omni-directional Two Way Wireless Glass Break Detector, providing detection coverage of 180° measured from the sensor to the point on the glass farthest from the sensor.

The SH-GBD detector transmits series of messages for full communication administration (Alarms, Supervision, Tamper Status, Battery Status, Configuration, etc.) as well as test transmission signals.

- Freewave2™ Two Way ISM
- GFSK with 5 frequencies & LBT
- Frequency Band: 868MHz, 915MHz
- Low current Technology
- Powered by 2 Lithium batteries Type AA 1.5 Volt
- Battery life : up to 5 years
- Back Tamper (removal protection)
- Supervision transmission
- Battery status signal transmission
- Unique ID number (24 bits)
- Configurable over-the-air

PRODUCT OVERVIEW

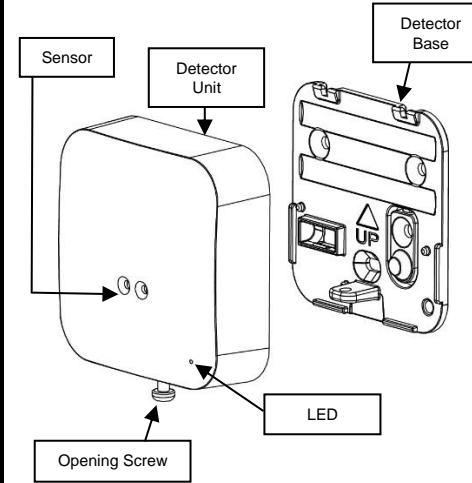

Figure 1

DETECTOR OPENING

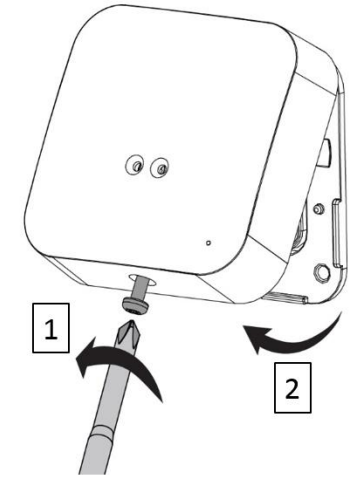

Figure 2

1. Unscrew the bottom screw
2. Tilt out the detector unit and separate it from its base.

BATTERY INSERTION AND REPLACEMENT

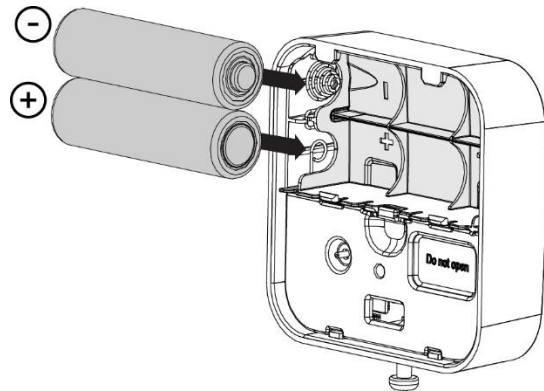

Figure 3

The battery can be replaced by the user
Battery type: 2 Batteries Lithium 1.5V, Type: AA

CAUTION

RISK OF EXPLOSION
IF BATTERY IS REPLACED BY DIFFERENT TYPE / MODEL.

DISPOSE USED BATTERIES
ACCORDING TO ITS INSTRUCTIONS

DETECTOR MOUNTING

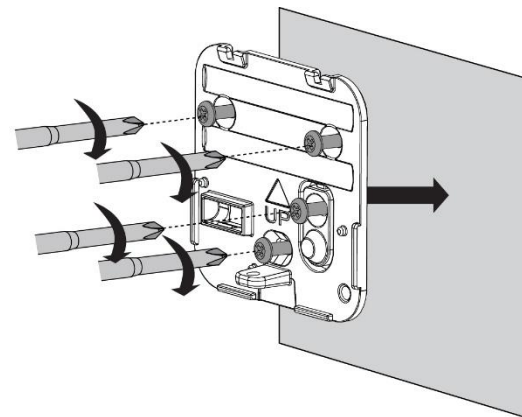

Figure 4

We recommend using the hole in front of the tamper switch to enable the protection against removal.

After base mounting, replace the detector unit by tilting it in the base.

Screw the holding screw and wait LEDs stop blinking before proceed with learning step.

DETECTION COVERAGE

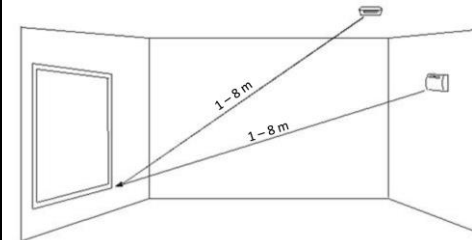

Coverage is measured from the detector to the point on the glass farthest from the detector.

The detector can be mounted as close as 1m from the glass.

1. Mounted on opposite wall or Adjoining walls, range is 8m for plate or glass.
2. Mounted on the ceiling, maximum range is 6m for plate, tempered, laminated and wired glass.
3. For armor-coated glass, mount sensor no more than 3.65m from glass.

LEARNING PROCESS

For pairing process, please refer to your control panel instructions.

To pair your device with Shepherd™ panel, please proceed as follows:

1. Enter in installing mode via the "Installer Webpage"
2. Go to "Zones" and select the zone you want to learn
3. Enter the unique radio device ID, and then send the configuration to the control panel
4. Place a battery as instructed in Figure 3 and wait until the Red LED stops blinking.
5. The device should register to the Control Panel.
6. When registration process is successfully completed, the Green LED will constantly light ON for 3 seconds and then turn OFF.

If registration process failed, the Red LED will blink. Remove the battery, wait for few seconds (~10sec) and repeat the learning process.

DETECTOR TESTING

Proper Testing

The SH-GBD is designed to detect the breaking of framed glass mounted in an outside wall. Testing the detector with unframed glass, broken bottles, etc., may not trip the detector.

The SH-GBD typically does not trip to glass breaking in the middle of the room no burglar breaks glass in the middle of a room, so such breaks are false alarms.

NOTE: SH-GBD may not consistently detect cracks in glass, or bullets that break through the glass. Glass break sensors should always be backed up by interior protection.

Recommended Glass Size

Minimum	0.4m x 0.4m or larger
---------	-----------------------

USE GLASS BREAK TESTER

You can use a glass break tester to check the functioning of the detector and the conformity of the installation. (Refer to the manual of your Glass Break tester to select the appropriate mode for testing).

When the Red LED on the detector goes solid shortly while the tester is triggered, the glass is within detection range.

If the LED does not go solid, but simply continues blinking, reposition the detector closer to the protected windows and retest. This may require adding additional detector(s) in order to achieve adequate coverage.

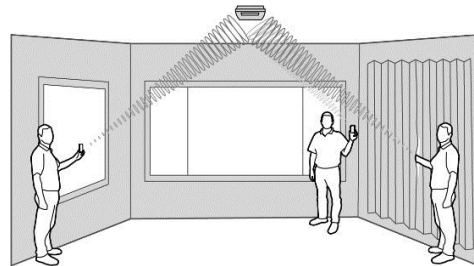

EVENT TRANSMISSION

SUPERVISION– A periodical transmission (configurable) indicating detector's presence.

ALARM – Alarm transmission triggered by the device indicating Shock and Glass break detection. The Red LED will blink once.

LOW BAT – Whenever the battery reaches the low level (2.9V), a "Battery Low" signal will be sent. When Battery level drops below Cut Off level (2.5V) the device will stop functioning and the Red LED will blink for 10 seconds and then turned Off.

TAMPER – Whenever the detector unit is removed from its base or the device is tear off from the wall, a "Tamper" signal will be transmitted to the control panel.

RSSI – RF SIGNAL INDICATION

After learning and before installing the detector we recommend to perform walk and transmission tests.

Tamper Transmission Test

Changing the tamper switch state (by attaching / removing the device to / from the Base) will cause tamper transmissions.

Alarm Transmission Test

During the detector test (using glass break tester), verify RSSI signal level received on your control panel.

Note: See control panel installation instruction.

SPECIFICATION

Detection Method	Omni-directional Shock & Glass Break Sensor
Communication Protocol	Freewave2™ Two Way ISM GFSK with 5 frequencies & LBT
Modulation Type	GFSK (5 frequencies)
Frequency	868-869MHz / 916-917MHz
Identification	Unique ID serial number – 24 bit
Events Transmission	Alarm, Tamper, Supervision, Low Bat.
Supervision Time	7 min by default (<i>configurable</i>)
Range	Up to 500m in open space
Coverage Area	Up to 8m - 180° radius
Battery	2 Batteries Lithium 1.5V Type: AA
Battery life	Up to 5 years
Current Consumptions	Standby ~11 µA Receive mode ~24 mA Transmit mode ~45 mA Transmit power ~14 dBm
Tamper Switch	Back Tamper (Removal)
Operating temperature	-10°C to +55°C
Dimensions	85mm x 54mm x 21mm
Weight (inc. battery)	120 gr.

STANDARDS APPROVALS

The SH-GBD conforms to the essential requirements set out by:

EN 300220-1

EN 300 220-1

EN 300 220-2

EN 50130-4

EN 61000-6-3

EN 301489-1

EN 301489-3

EN 60950-1

EN 50131-2-7-1

EN 50131-5-3

EN 50131-1

EN 50130-5

Security Grade2, Environmental Class II
Power supply Type C



WARRANTY POLICY CERTIFICATE

Crow warrants these products to be free from defects in materials and workmanship under normal use and service for a period of 24 months from the last day of the week and year whose numbers are printed on the printed circuit board inside these products.

Subject to the provisions of this Warranty Certificate, during the Warranty Period, Crow undertakes, at its sole discretion and subject to Crow's procedures, as such procedures are from time to time, to repair or replace, free of charge for materials and/or labor, products proved to be defective in materials or workmanship under normal use and service. Repaired products shall be warranted for the remainder of the original Warranty Period.

All transportation costs and in-transit risk of loss or damage related, directly or indirectly, to products returned to Crow for repair or replacement shall be borne solely by the Purchaser. This Warranty Certificate does not cover products that is defective (or shall become defective) due to: (a) alteration of the products (or any part thereof) by anyone other than Crow; (b) accident, abuse, negligence, or improper maintenance; (c) failure caused by a product which Crow did not provide; (d) failure caused by software or hardware which Crow did not provide; (e) use or storage other than in accordance with Crow's specified operating and storage instructions.

There are no warranties, expressed or implied, of merchantability or fitness of the products for a particular purpose or otherwise, which extend beyond the description on the face hereof. This limited Warranty Certificate is the Purchaser's sole and exclusive remedy against Crow and Crow's sole and exclusive liability toward the Purchaser in connection with the products, including without limitation - for defects or malfunctions of the products. This Warranty Certificate replaces all other warranties and liabilities, whether oral, written, (non-mandatory) statutory, contractual, in tort or otherwise.

In no case shall Crow be liable to anyone for any consequential or incidental damages (inclusive of loss of profit, and whether occasioned by negligence of the Crow or any third party on its behalf) for breach of this or any other warranty, expressed or implied, or upon any other basis of liability whatsoever.

Crow does not represent that these products can not be compromised or circumvented; that these products will prevent any person injury or property loss or damage by burglary, robbery, fire or otherwise; or that these products will in all cases provide adequate warning or protection.

Purchaser understands that a properly installed and maintained product may in some cases reduce the risk of burglary, fire, robbery or other events occurring without providing an alarm, but it is not insurance or a guarantee that such will not occur or that there will be no personal injury or property loss or damage as a result.

Consequently, Crow shall have no liability for any personal injury; property damage or any other loss based on claim that these products failed to give any warning.

If Crow is held liable, whether directly or indirectly, for any loss or damage with regards to these products, regardless of cause or origin, Crow's maximum liability shall not in any case exceed the purchase price of these products, which shall be the complete and exclusive remedy against Crow.



sales@crow.co.il
support@crow.co.il

www.thecrowgroup.com

These instructions supersede all previous issues in circulation prior to December 2017